

Compat ella®

Compat Ella® Backpack

The Compat Ella® Backpack is intended for use with the Compat Ella® Enteral Feeding Pump and the Compat Ella® Backpack Insert/Table Stand, by either adults or children.

Features at a Glance

Smart Design:

- Large zippered compartment makes it **easy to install and remove Compat Ella® Pump**, Administration Set, and formula – without disconnection.
- Designed to work with the Backpack Insert/Table Stand for **ultimate convenience**.
- Administration Set tubing exit on left or right side.
- Padded back for **patient comfort** with chest and hip straps for **stability**.

Convenient:

- Compatible with most tube feed containers up to 1000mL.
- Zippered flap for **quick access** to check or program Compat Ella® Pump.
- Wide range of size adjustments makes it suitable for use by **children or adults**.
- Removable messenger strap gives **additional portability options** for wheelchair or as a messenger bag.

Robust and Modern:

- High quality materials, zippers and **water resistant** fabric protects Compat Ella® Pump on the go.
- Machine washable at 30°C.
- Discreet **modern and compact design** in black and grey.

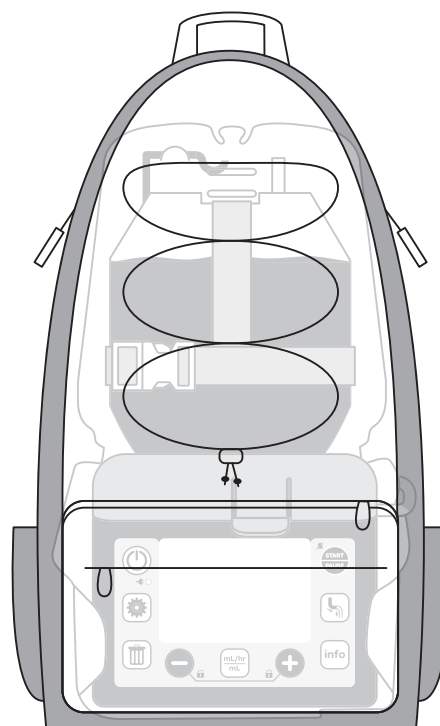

Ordering Information

Product Name	Product Code	Qty/Box
Compat Ella® Backpack	12277736	1

Have you met Compat Ella®?

Compat Ella® Backpack

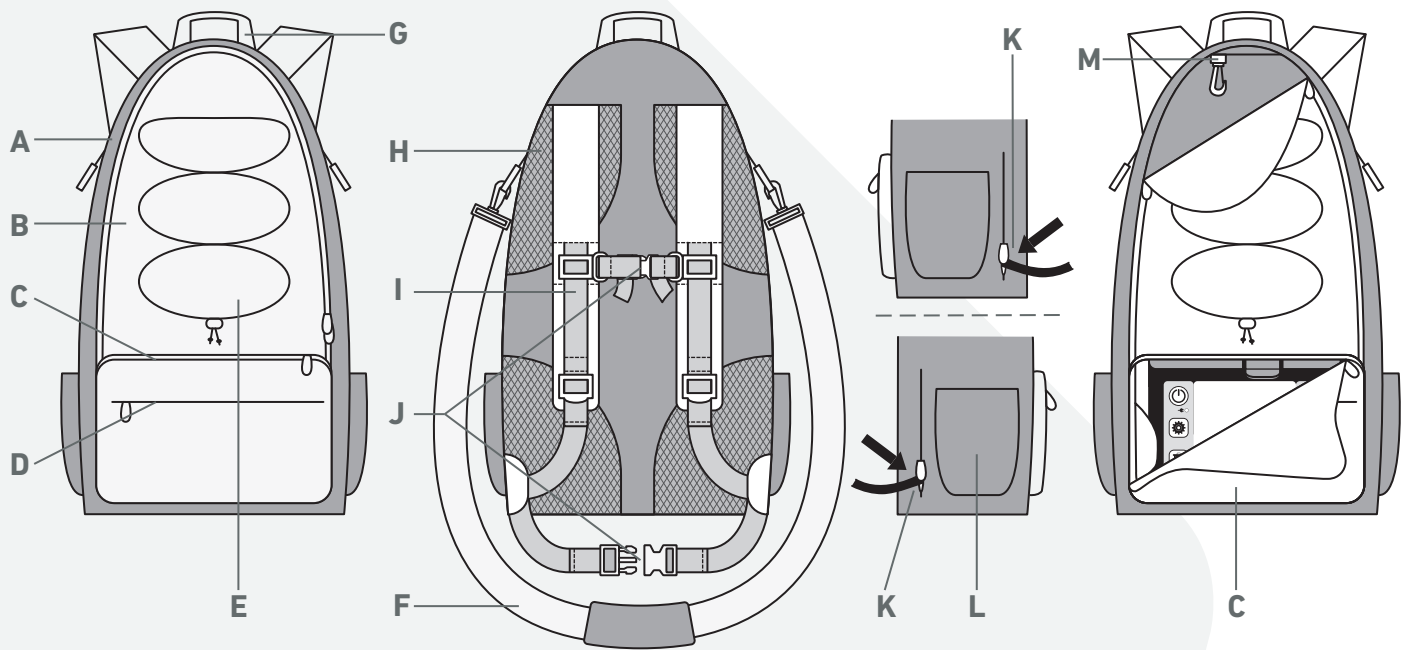

Components

- A Main compartment with dual zippers
- B 420D Nylon Ripstop fabric, with water resistant coating
- C Front flap for quick access to the pump
- D Zippered accessory compartment
- E Elastic webbing to secure small items
- F Removable wheelchair/messenger strap
- G External backpack hanger
- H 3D mesh padding for patient comfort
- I Adjustable shoulder straps
- J Adjustable chest and hips straps
- K Zippered side openings to allow tubing to exit from either left or right side
- L Side compartments for small accessories
- M Internal nutrition hanger

Specifications

- Packing:** Individually packed in cases of 1 piece (40 x 24 x 4,5 cm).
- CE Mark:** Complies with the European Medical Devices Directive 93/42/EEC.
- Classification:** Class I.
- Legal manufacturer:** Axium MTech S.A., Allée de la Petite Prairie 2, CH-1260 Nyon, Switzerland.
- Cleaning:** Machine wash at 30°C. Do not iron. Do not bleach. Do not tumble dry.
- Materials:** 420D Nylon Ripstop fabric.
- Country of origin:** Made in China.

To obtain further information please contact your Compat® representative or go to www.compat.com
®Unless stated otherwise, all trademarks are owned by Axium MTech S.A. or used with permission.

AXI00013 REV.1 16 MARCH 2021

Compat®